

Thanks for using this capacitance power source for magnetizing.

Special notice:

This magnetizing power source is special multi-polar and pulse power source. It must be equipped with the special multi-polar fixtures of our company or the fixtures that have the same standard. Incorrect connection or change of the fixture and short of the output will scrap the product and damage the equipment!

This magnetizing power source works under high voltage and great current, the user must act according to this manual. Any factor from the electric net, incorrect use will damage the equipment and endanger the personnel safety. Read the manual before using the equipment in order to get the best results.

Our company is always applying itself to improve the quality of the products. We hold the right to improve the product standards and technical parameters in his manual without informing in advance. At the same time, we try our best to ensure the exactness of the data without taking on any responsibility to any fault or leak.

Our company will offer you quick and give technical support at the same time with improving the product quality.

Catalog

1,Summary.....	1
2.Work theory.....	2
1) The name of DCD series magnetizing power source	2
2) Work theory.....	3
3.Techinial parameters.....	4
1) Work condition	4
2) Technical parameters.....	4
4.Name and function of each part	5
5.Using methods.....	9
1) Installation	9
2) Using methods.....	10
6.Maintenance.....	12
7.Circuit diagram and explain of the legends.....	13
8.Magnetizing power source series parameters.....	14

1.Summary

In recent years the require o magnetizing equipments becomes higher and higher with the development of permanent materials. The coercive force of permanent materials becomes bigger and bigger. So the production efficiency must be improved. This problem puzzles also large multi-polar magnetizing industry at the same time. If we still use old magnetizing power source with single-phase output, the magnetized (magnetizing plate, multi-polar magnetizing fixture) becomes more difficult, and magnetizing quality cannot be ensured. These are factors that can block the

development of the field of mold magnetic and multi-polar products. In order to solve the problems above we have designed DCD magnetizing power source intentionally. This type of power source breaks up the whole into parts and enhances the reliability and flexibility of the system. This series has advanced controlling system and bran-new design of the power source. This makes its magnetizing efficiency better than the efficiency of the former magnetizing power source. In the field of mold magnetic industry, It makes that it is possible to use production line of high efficiency in the mold magnetic field. It reduces the working procedure of cutting out mold magnetic materials because of small magnetizing area. At the same time it reduces wastage because of several times' cutting out and machining cost of producing once more. The products from the product line, finished or semi finished, can be carried in coils. These all will promote the development of the mold magnetic production field .In the multi-polar magnetizing field; It can also bring the magnetizing field of large multi-polar magnetic materials revolutionary change. With special magnetizing fixtures the power source to magnetic pole discharging and magnetizing can be performed. This type of magnetizing has good results and high efficiency. Producers can use better production technique to bring permanent materials into full play. It makes that one use this power source flexibly.

2Work theory

2.1 The name of DCD series magnetizing power source

There is 3types and 30models of DCD series magnetizing power source that fully meeting the demand of magnetizing, Such as ferrite material and rare earth material multi-polar magnetized. The name of DCD series magnetizing power source is below:

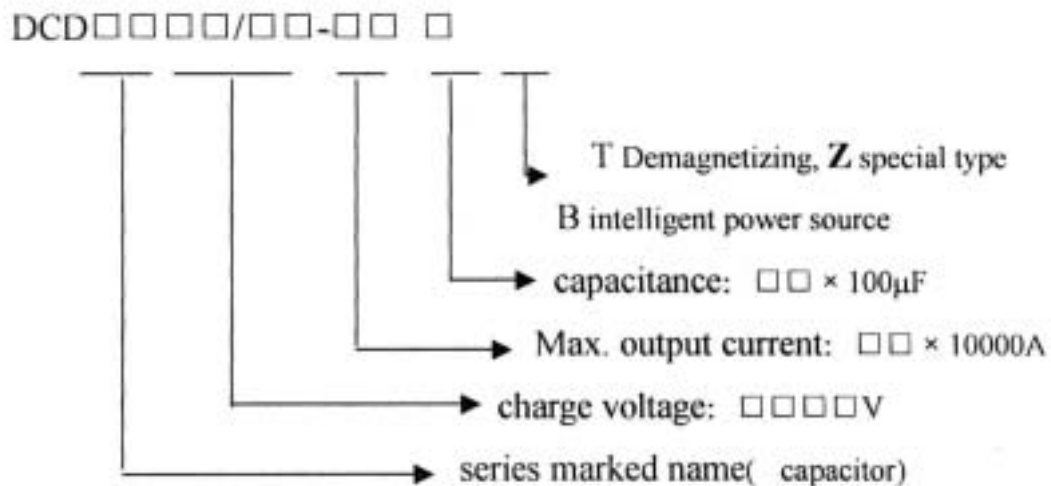

You can learn the product electric parameter by the name. Using formula $P=(1/2)CU^2$ you can calculate the max. Energy of the product. For example, DCD-2000/5-16T has max. Charge voltage 2000V,max.current more than

50000A(short circuit current), capacitance 1600 μ F. The energy of this product is
 $P=(1/2)*1600*10^{-6}*2000^2$
 $P=3200J$

2.2 structures

The sketch map of this power source for magnetizing is as following.

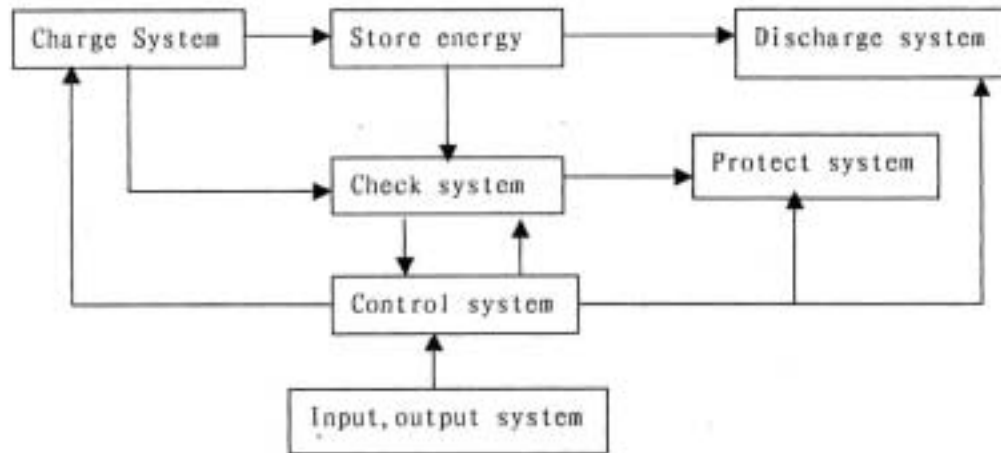

chart 2 system structure

From the chart above we can see, after the magnetizing power source have received indications from outside (charging, demagnetizing magnetizing), 220V50Hz alternation current will be stepped up by time energy storing machine is charge through communication system. When the charging voltage, which is checked by voltage checking system., is the same as the voltage which is set before, the controlling system will close the charging system, stop charging and wait for magnetizing(demagnetizing) indications and send out these indications(show only by remote-control). At the same time, when the checking system finds that the voltage of the energy storing capacitor is low, it will start the charging system. And reinforce electricity to the energy storing capacitor. It will not stop until the magnetizing power source receives indications. After the input system have received magnetizing (demagnetizing) indications (plate indications or remote control indications), the SCR will be open and the energy of capacitor will be released through the fixture. In the center of the fixture a strong magnetic field will come into being, magnetizing will be finished soon, and then the controlling system will come back to the original state. If the automatic function of the input system is in effect, the controlling system will bring the charging system into the next period work to charge after it come back to the original state.

The charging check checks mainly the charging voltage of the energy storing piece and the terminal protection voltage. If there is something wrong with the charging

system, that is to say, the charging voltage is higher than the highest voltage set by the system, the checking system will cut off the main communication contact equipment, and let out the charge on the energy storing piece through the inside discharging resistance. This checking system uses separate check and concentrated control.

3. Technical parameters

3.1 Work conditions

Voltage: 220V \pm 10%

Frequency: 50Hz

Environmental temperature: -10 -- + 40 °C

Elevation: \leq 1000m

3.2 Technical parameters

Name: capacitance power source for magnetizing

Type: DCD-2000/5-16T

Input current(A): \leq 20A

Voltage to charge (V): 50V-2000V

Maximal work period: 9s

Discharge time: \leq 100 μ s (depend on the fixture)

Maximal output current (A): 50000A

Capacitance (μ F): 1600 μ F

Volume (mm^3): 600X800X1400

Weight (Kg): 600

4 Name and function of each part

(1) On –off button of the power: While pressing the button, it will be locked by itself and the red light on it will be bright. It means that the power source is turn-on.

(2) Button with automatic function: While pressing it, the button will be locked by itself and the green light will be bright. It means that the power source is working under the state of being charged by itself. It makes the power source be charged automatically after one work period without that operators press the button again. This function can improve work efficiency.

(3) Button with demagnetizing function: While pressing the button, it will lock by itself and the yellow light on it will be bright. It means that the power source is working under the state of demagnetizing function. (only for that have demagnetizing function product)

(4) Perform-button to magnetize: While pressing button, the green light will be bright. It means that the operation begins. When the light turns off, the operation finished.

(5) Perform-button to charge: While pressing the button, the red light will be bright, that means the operation begins. When the light turns off, the charge is over. The next operation can be performed.

(6) Button to adjust voltage: It is used to adjust the charging voltage continuously. The adjusting of the voltage is only in effect during and after charging. It is useless at any other time. But by net charging, it will be charged at the last adjusting voltage.

- (7) Voltage meter: It shows the voltage value of the capacitor.
- (8) Equipment nameplate.
- (9) Remote-control electrical outlet: used with remote-control connector plugs, which are accessories, to make control of the magnetizing at different places. Remoter-control connector plugs 1 and 2 meet on-off contact, 3 and 4 meet remote-control LED, 3meets (+) of the LED, 4 meets (-) of the LED.
- (10) Additional power outlet of the power source: used with the additional power connector plugs which are equipment accessories, to offer peripheral equipment of the magnetizing power source 220V50Hz alternating current..
- (11) Output connector of thee power source for magnetizing: connect magnetizing fixtures with magnetizing power source.
- (12) Power source plug: used to connect 220V 50 Hz alternations current.
- (13) Outline hole: connect fixtures with magnetizing power source through the holes

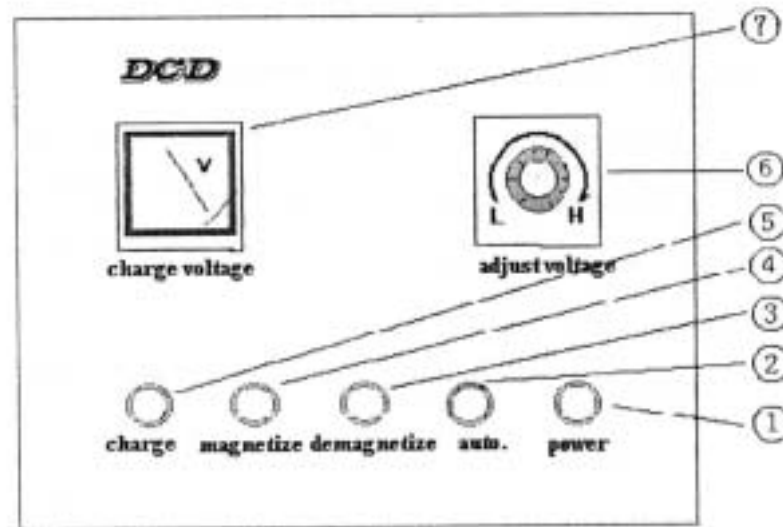
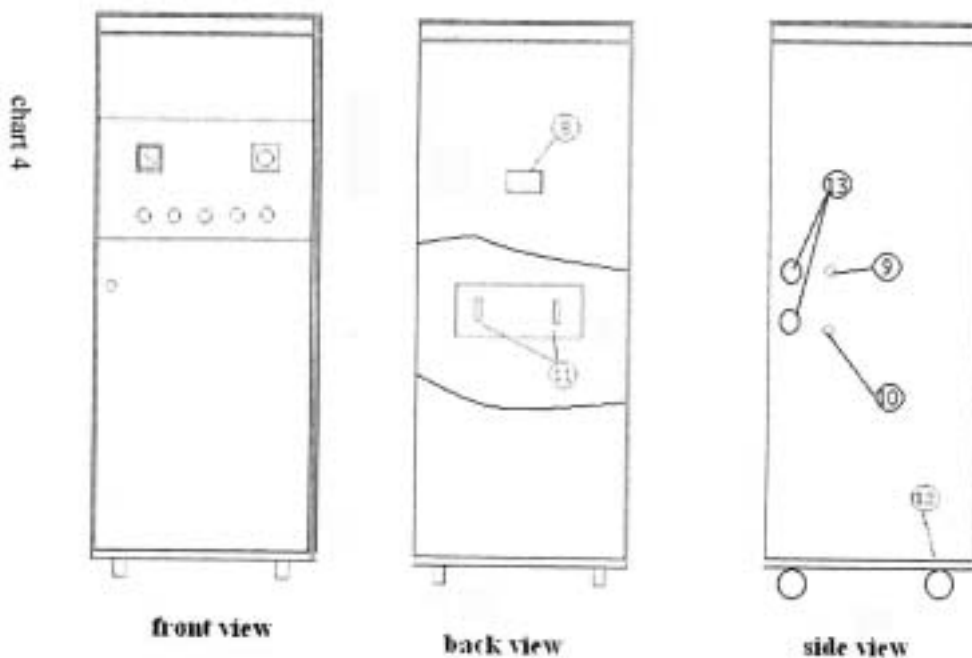

chart 3 operation plates



5 Using methods.

5.1 Installation

(1) Installation of the equipment

Put well the main machine tank and the assistant machine tank of the power source for magnetizing according to chart 4.

When you open the front and back door of the equipment, you will find copper rows for connection. Please connect them according to the color.

Notice: the connection must be firm.

(2) Installation of the power source:

The installation of the power source will influence its work situation directly. Before using this power source for magnetizing please ensure right installation and pay attention to the following points:

- 1) On the power net, which is used by the power source for magnetizing, frequency conversion, middle or high frequency, or mix-phase equipments that need high-power cannot be used at the same time. When processing corresponding conditions, one can use electrical net of one way singly or add wave-sieving equipments.
- 2) Layout must be performed according to the technical parameters. The coming-into thread must be three -phase and four line, zero line and terra line clearly. Their connections must be firm.
- 3) If peripheral equipments need electricity, please use standby power source or other power sources.

4) The crust of the machine must be fixed with ground line reliably.

(3) Install fixtures

Connect the fixture lines with power source (11 in chart 4) through the outline hole (13 in chart 4).

5.2 Using method

(1) Magnetize manually

- 1) Press button of the power source (1), and the indicator light will be bright. It show that electrify is in order.
- 2) Modulate the automatic on-off button (2) to the state with hand (the indicator light of this button is not bright).
- 3) When magnetizing at the first time, one cannot know the magnetizing voltage, please modulate the button to minimal place.
- 4) Press the charging button (5), the button will go out after flashing. It shows that charging is finished. Regulate button (6) until the voltage meter (7) shows something. Regulate the magnetizing voltage according to production technique. Loosen the button (6); the value on the voltage meter doesn't go up any more. The electricity filling function begins to work.
- 5) Press magnetizing button (4), the indicator light of the button will go out after flashing. The value on the voltage meter is 0, and it show that magnetizing is finished.
- 6) When magnetizing is not good, regulate charging voltage until it is suitable for magnetizing.
- 7) After regulating the magnetizing voltage, press the charging button (5). After charging, press the magnetizing (4). Repeat magnetizing manually.

(2) Magnetize automatically

- 1) Press automatic on-off button (2). The green light will be bright and it means the automatic function is in effect. If one has charged before pressing this button, the magnetizing power source will charge at once. If one has not charged before pressing the button, he must charge with hand at first. In the future the magnetizing power source will charge automatically. The operator presses the button to magnetize automatically, and then magnetizing will be performed.
- 2) Act from 1) to 4) according to magnetizing manually.
- 3) Press magnetizing button (4) or use remote control magnetizing on off which is obligated by remote-control electric outlet (9), remote control magnetizing can be performed. If this magnetizing power source is equipped with magnetizing fixture of our company, you can find a remote-control magnetizing button and an indicator light that shows waiting for magnetizing. After charging this light will be bright. It means the operator at the different place can magnetize. The operator presses the remote-control magnetizing button on the magnetizing fixture, and then magnetizing can be performed.

(3) Manual and automatic demagnetizing (only for the power source has demagnetizing function)

Especial notice:

To make-work more safe and reliable, this series of magnetizing power sources has an especial function. That is, when pressing the magnetizing button, the magnetizing power source will stop charging. With this function it is very easy to control charging at different places.

Because this equipment works under high voltage and great current, there will be strong electromagnetic power and it will make the piece to be magnetized shake. This will influence the effect of magnetizing and demagnetizing. When serious, the piece to be magnetized will fly out of magnetizing loop and arise unnecessary damage. So please press out the piece before magnetizing it.

6. Maintenance

This magnetizing power source belongs to equipment s that uses high voltage and great current. So users must pay attention to maintenance besides performing work experience by operating electricians.

- 1) Because this equipment works under high voltage, please pay especial attention to moisture proof treatment of the work environment
- 2) Because this equipment works under high voltage, please pay especial attention to the density of the environmental powder. The equipment should be got rid of powder once half a year.
- 3) Because this equipment works under high voltage and great current, long timework will make fasteners flexible, and it will influence magnetizing results. So examination should be carried through once three months to prevent fasteners from becoming flexible.

7. Electrical theory chart of the magnetizing power source

B: transformer

V: Voltage meter

BLQ: convertor

Y: alarm

BHB: circuit plate for protection
rectifier

SCR: Silicon controlled

BX: safety

TXMK: model of regulate phases

C: capacitance

KDY: on-off of the power source

CZ: connection end row

KTC: on-off for demagnetizing

CCD: light for magnetizing

KZD: automatic function on-off

CDD: light for charging

KZB: plate for controlling

DCC: light showing that it is waiting for magnetizing. It is used only by
remote-control

RDT: Voltage-regulate-button

JP: connector plugs, electrical outlet

KCD: button for charging

JCB: circuit plate for examining

J: relay

JSQ: number counting implement

R: resistance

KCC: button for magnetizing

8. series magnetizing power source parameters

economical type magnetizer

Model	Output voltage	Work cycle	Capacitor	Energy	Weight	Dimension
DCD-900-66Z	50 - 900V	30s	6600 μf	2673J	40kg	350Wx500L x800H
DCD-900-132Z			13200 μf	5346J	45kg	
DCD-900-198Z			19800 μf	8019J	60kg	
DCD-900—264Z		60s	26400 μf	10692J	200kg	600W x 650L x 1600H
DCD-900-528Z			52800 μf	21384J	240Kg	
DCD-900-792Z				79200 μf	32073J	280Kg
The user can get additional fixture that do not be paid.						

Small magnetizer

Model	DCD-1100/1-6 DCD-1100/1-6T	DCD-1100/1.5-12 DCD-1100/1.5-12T	DCD-1100/2-24 DCD-1100/2-24T
Power line	Single phrase, 220V, 10A		
Max. current	10000A	15000A	20000A
Work cycle	1s	2s	4s
Out voltage	50 ~ 1100V continue modulate		
Capacitance	600 μf	1200 μf	2400 μf
Energy	363J	726J	1452J
Dimension	350W x 500L x 800H		
Weight	40kg	45kg	60kg
Demagnetizing	"T" means demagnetizing function		

High energy magnetizer

Model	DCD-1100/ 00/ 1.5-48 DCD-1100/ 00/ 1.5-48T	DCD-1100/ 2.5-96 DCD-1100/ 2.5-96T	DCD-1100/ 4-192 DCD-1100/ 4-192T	DCD1100/ 5-384 DCD-1100/ 5-384T	DCD-1100/ 5-384 × n DCD-1100/ 384T × n
Power line	Single phrase, 220V 40A			Single phrase, 220V 40A	Three phrase, 380V 40A
Max current	15000A	25000A	40000A	50000A	50000A × n
Work cycle	5s	9s	9s		
Out voltage	50 ~ 1100V continue modulate				
Capacitance	4800 μf	9600 μf	19200 μf	38400 μf	38400 μf × n
Energy	2904J	5808J	11616J	23232J	23232J × n
Dimension	600×650×1600		600×800×2000	(600×2) × 800×2000	600×(n+1) × 800×2000
Weight	200kg	260kg	400kg	(300+600)kg	(300+600×n) kg
Demagnetizing	"T" means demagnetizing function				

Great current magnetizer

Model	DCD-2000/5-16 DCD-2000/5-16T	DCD-2000/10-32 DCD-2000/10-32T	DCD-2000/5-16 × n DCD-2000/5-16T × n
Power line	Single phrase, 220V, 30A		Three phrase, 380V, 30A
Max current	50000A	100000A	50000A × n
Work cycle	5s	9s	
Out voltage	50 ~ 2000V continue modulate		
Capacitance	1600 μf	3200 μf	1600 μf × n
Energy	3200J	6400J	3200J × n
dimension	600×650×1600	600×800×2000	600×800×2000
weight	260kg	400kg	(300+150kg×n)kg
Demagnetizing	"T" means demagnetizing function		